

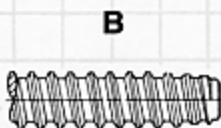

TYPES

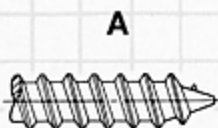

THREAD ROLLING SCREWS

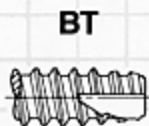
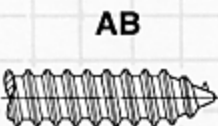

SELF DRILLING SCREWS



TESTS

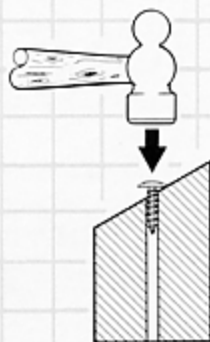

DUCTILITY

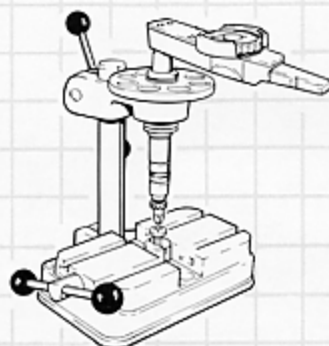

TORSIONAL STRENGTH



DRIVE TEST

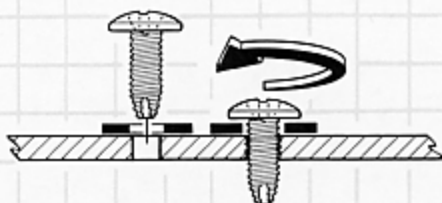

DRIVE TORQUE

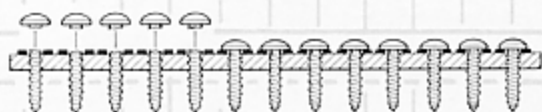

HYDROGEN EMBRITTLEMENT

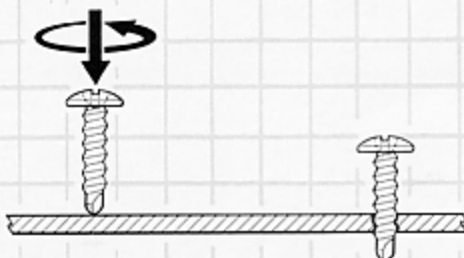

DRILL-DRIVE

PRICE: \$5.00 U.S.

NEW ADDRESS!

Greenslade & Company

2234 Wenneca Street
Fort Worth, TX 76102

817-870-8888, 817-870-9199 Fax



(800) 435-2657

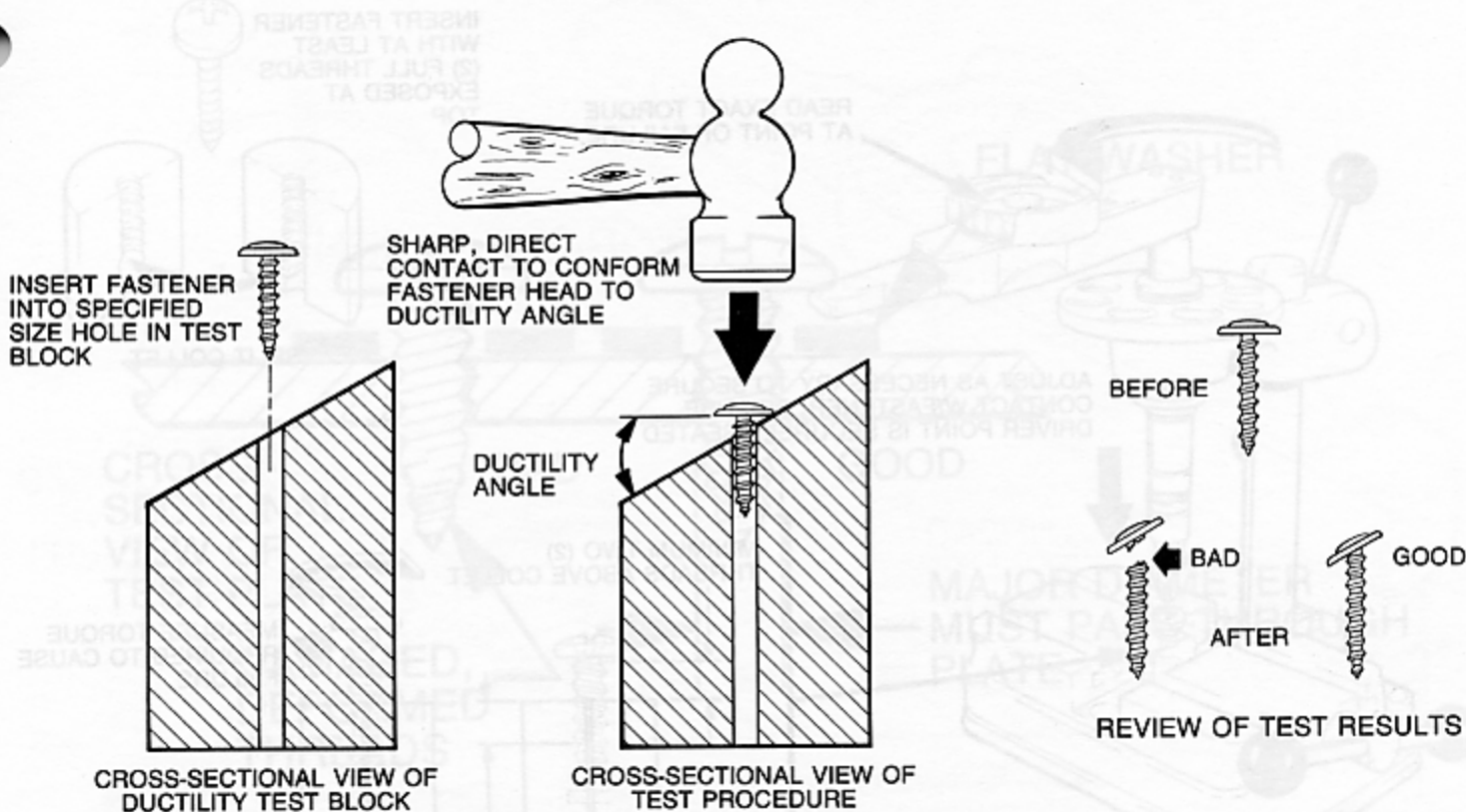

DUCTILITY TEST

1. DUCTILITY TEST

Applicable To:
Test Purpose:

Specification:
Apparatus required:

Minimum Recommended
Sample Size:
Procedure:

Failure:
Possible Failure Causes:

All Tapping Screws.

To detect detrimental brittleness which may cause heads to break off during driving or seating or when impact stresses occur in the application.

10 Degree bend for all Tapping Screws except 5 degrees for Self Drilling Screws.

- A. Ductility Block (DB-010 or DB-005).
- B. Small Hammer (DH-100).

8 pieces per lot; lot size not to exceed 250,000.

- A. Place screw in the appropriately marked hole on the block.
- B. Strike on top of the head with a hammer so that the bearing surface of the part conforms to ductility block angle.
- C. Inspect.
The part has failed if the head separates completely from the shank.
- A. Core Hardness too high.
- B. Case Hardness too deep.
- C. Recess in head too deep.
- D. Underhead radius too small.



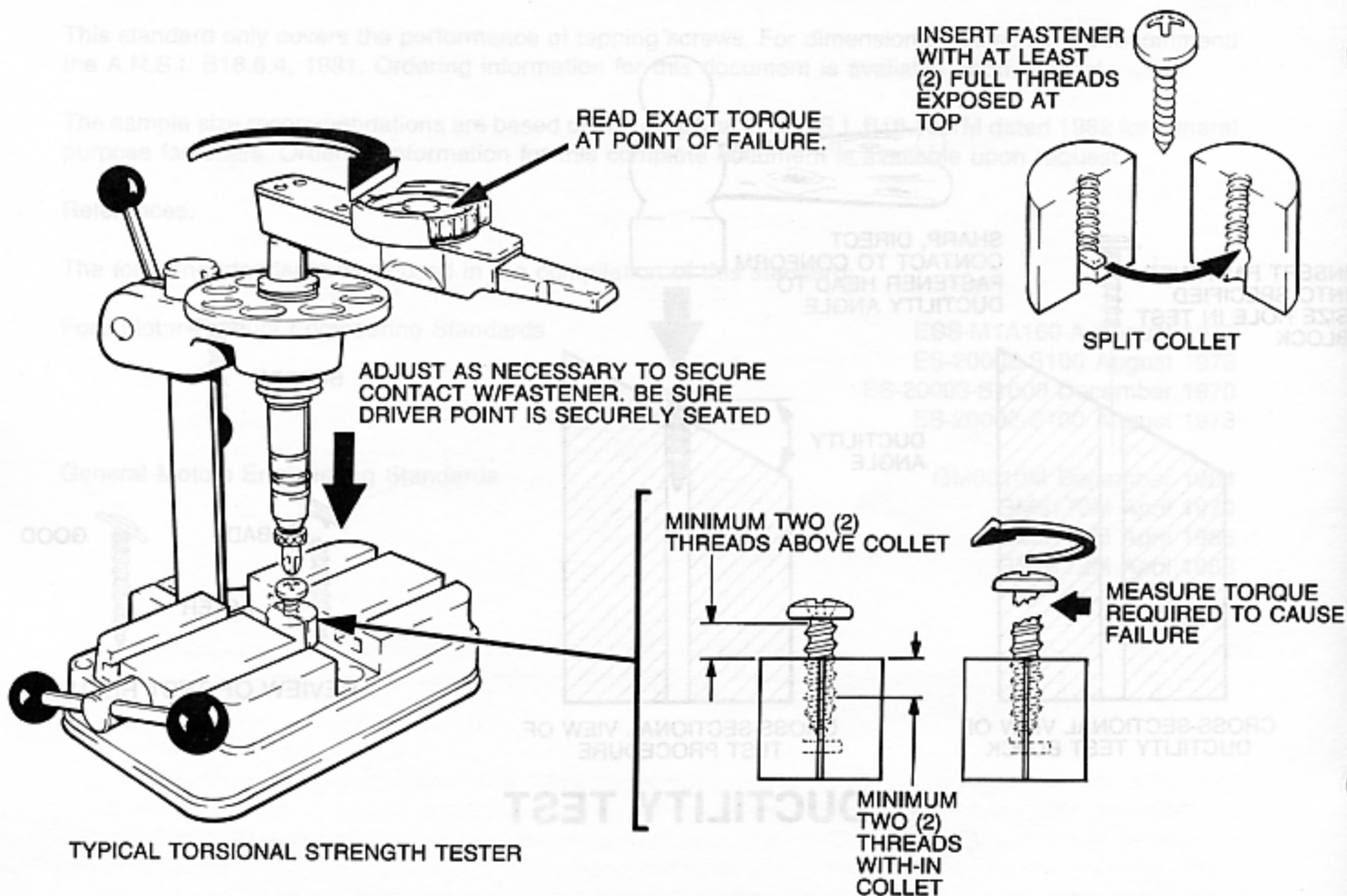

TORSIONAL STRENGTH TEST

2. TORSIONAL STRENGTH TEST

Applicable To:

Test Purpose:

Specification:

Apparatus required:

Minimum Recommended

Sample Size:

Procedure:

Failure:

Possible Failure Causes:

All Tapping Screws.

To detect parts having low strength which might twist off during driving or seating.

See charts that follow.

A. Appropriate Split Collet (SCxx-xx).

B. Collet Holder (SCH-250).

C. Screw Testing Fixture (STF-250).

D. Torque Wrench; accurate with $\pm 1-2\%$ (TW-xxx).

4 pieces per lot; lot size not to exceed 250,000.

A. Place the split collet into the collet holder and screw the fastener into the collet such that a minimum of 2 full threads are in the collet and a minimum of 2 threads are above the collet.

B. Place the collet holder in the screw testing fixture and clamp into place.

C. Apply torque with a torque wrench until the part twists off.

D. Record failure value and compare to the required specification.

Part twists in two at less than specified minimum.

A. Core Hardness too low.

B. Case Hardness too low.

C. Case Hardness too shallow.

D. Minor diameter too small.



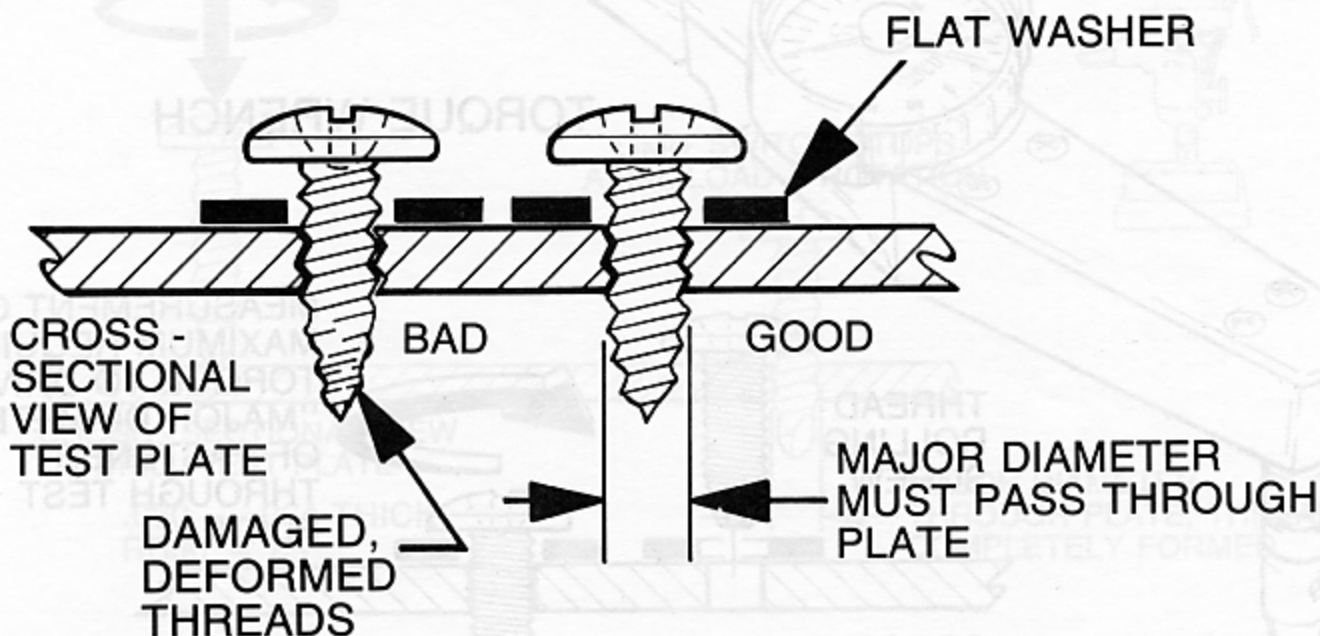

DRIVE TEST

3. DRIVE TEST

Applicable To:

Test Purpose:

Specification:

Apparatus required:

Minimum Recommended

Sample Size:

Procedure:

Failure:

Possible Failure Cause:

All Tapping Screws except BT(25).

To detect parts whose threads may collapse during installation, causing parts to drive improperly or not at all.

See charts that follow.

A. Appropriate test plates (TP-xx-xx).

B. Driving tools (power driver optional; do not exceed 500 RPM).

4 pieces per lot; lot size not to exceed 250,000

A. Drive parts into test plates until a full major diameter thread is formed completely through the plate. Lightly oil plain finished screws.

B. Inspect the threads which have penetrated the plate.

Note: This test can be performed in conjunction with the "Drive Torque Test" and the "Hydrogen Embrittlement Test."

The parts have failed if the threads which penetrated the plate have deformed to any extent at all.

A. Case Hardness too shallow.

B. Case Hardness too low.

C. Test Plate too hard.

D. Test Plate hole too small.



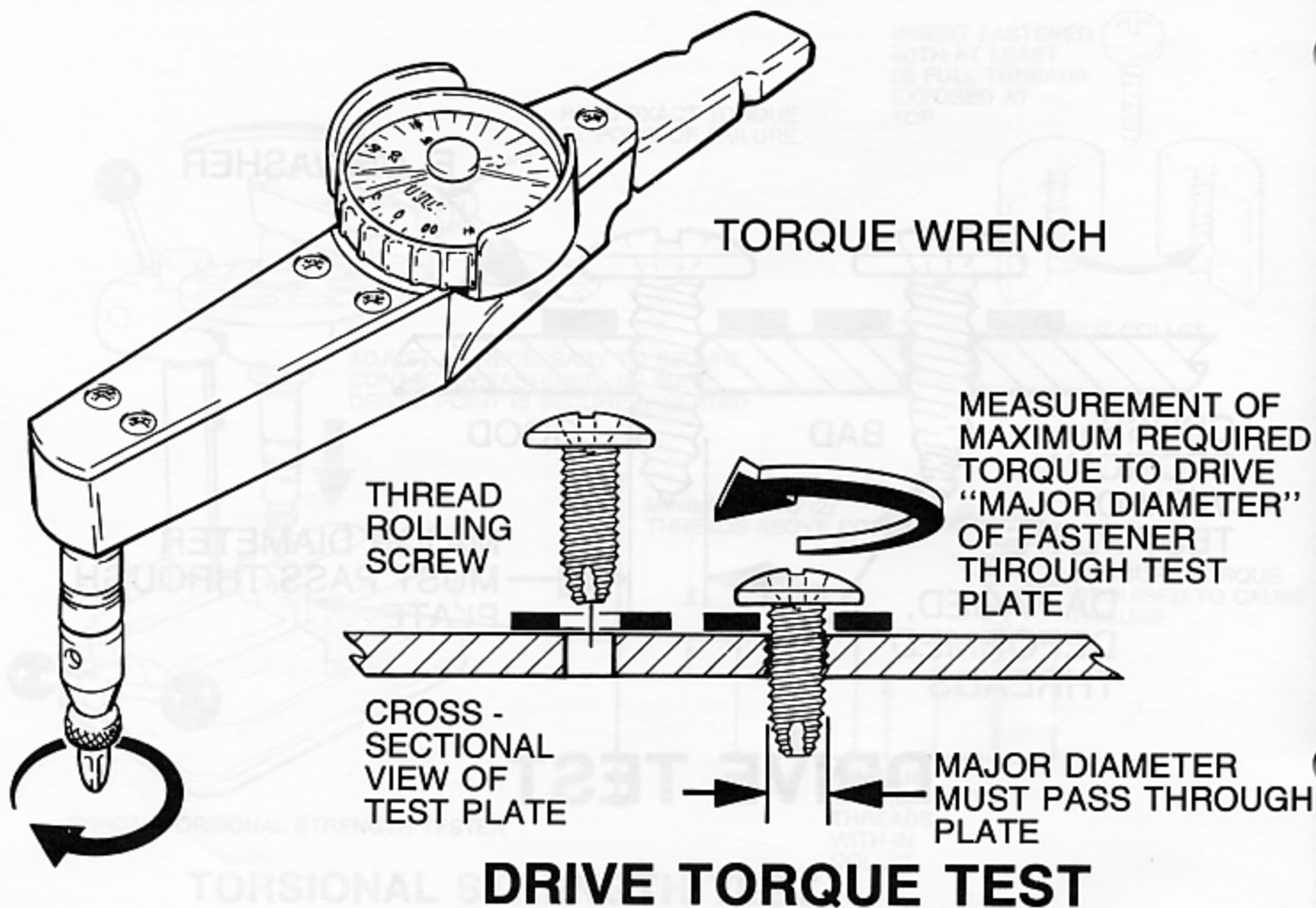

4. DRIVE TORQUE TEST

Applicable To:
Test Purpose:

Specification:
Apparatus required:

Minimum Recommended
Sample Size:
Procedure:

Failure:
Possible Failure Causes:

Thread Rolling Screws only.

To detect parts which have excessive driving torque requirements which will make driving and assembly difficult and may prevent components from being properly clamped together. See charts that follow.

- A. Specified test plates (same as those for "Drive Test").
- B. Torque Wrench, accurate within $\pm 2\%$ (TW-xxx).

4 pieces per lot; lot size not to exceed 250,000.

- A. Drive screws into the specified test plate with a torque wrench until a full major diameter thread completely penetrates the plate. Lightly oil plain finish parts.
- B. Record the highest torque value.

Note: This test can be done in conjunction with the "Drive Test" and "Hydrogen Embrittlement Test." The parts have failed if value recorded exceeds the maximum specified in the following chart.

- A. Forming feature of screw not properly formed.
- B. Case Hardness too low.
- C. Case Hardness too thin.
- D. Test Plate hardness too high.
- E. Test Plate hole size too small.
- F. Parts may need to be oiled or waxed.



TAPPING SCREW PERFORMANCE SPECIFICATIONS

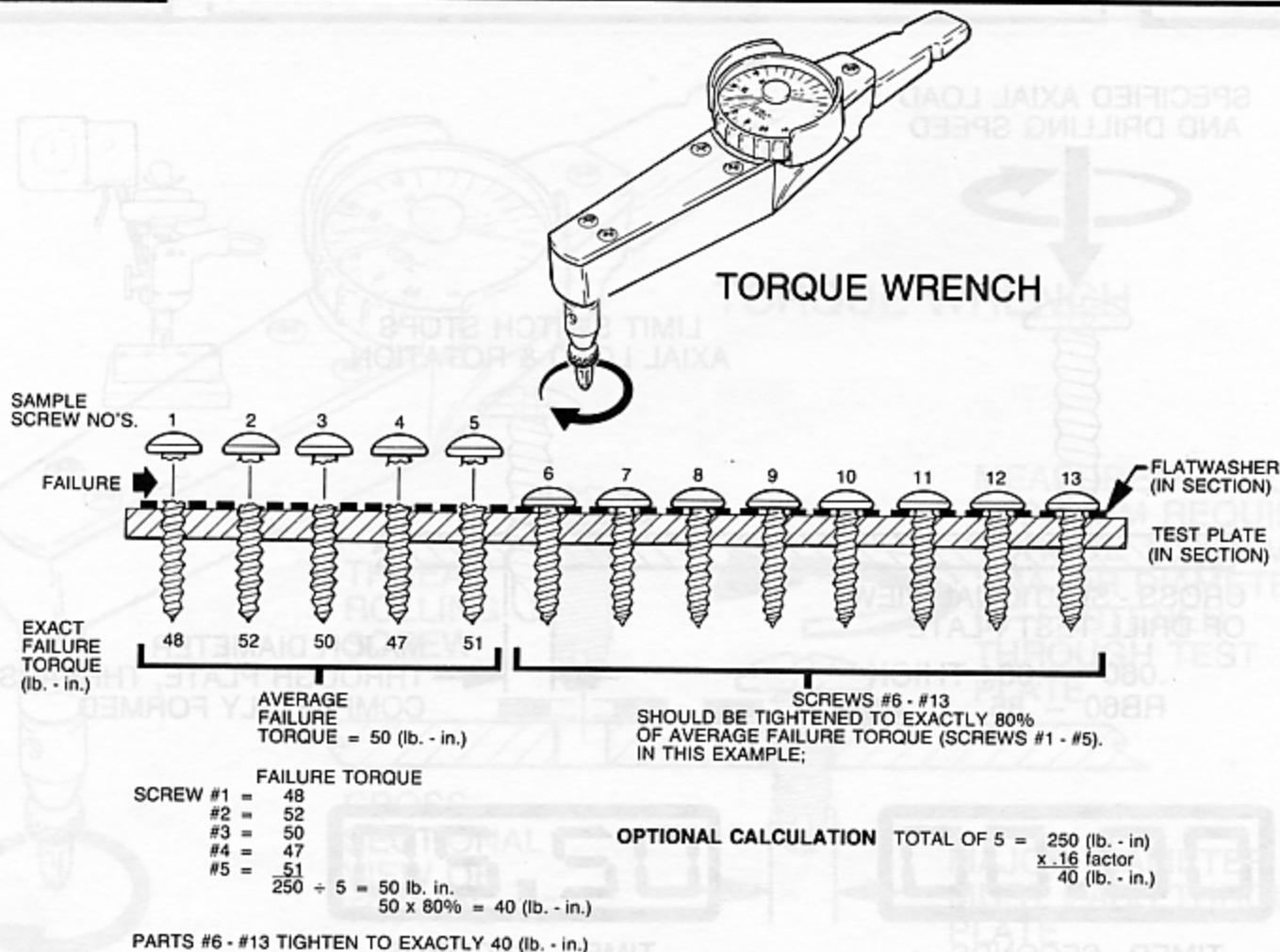

HYDROGEN EMBRITTLEMENT TEST

6. HYDROGEN EMBRITTLEMENT TEST

Applicable to:
Test Purpose:

All electroplated Tapping Screws.

To detect parts which may have a delayed failure up to 24 hours after installation in the assembly resulting from hydrogen induced during cleaning or plating. This is a particularly damaging failure because, unlike other types of failures, it does not occur at the time of assembly but only hours after the assembly is made. Its detection and correction after assembly can be costly, involving extensive disassembly, rework and reassembly, or in some cases, complete scrap.

Warning:

As a precaution all electroplated tapping screws should be baked after plating a minimum of 4 hours at temperature at 400 degrees Fahrenheit. This should be specified on all purchase orders.

Specifications:

Parts must not fracture within 24 hours after being seated at 80% of the average failure torque of 5 parts from the same lot.

Apparatus required:

- Specified Test Plates
- Flat Washers
- Torque Wrench; accurate within +/-2% (TW-xxx).

Minimum Recommended

8 pieces per lot; lot size not to exceed 250,000.

Sample Size:

A. Place washers on 13 screws to ensure that the parts are seated completely on the underside of the head and not on a shoulder or underhead radius. Total thickness of washers should be .080 minimum.

Procedure:

B. Drive all 13 screws into the correct test plate but do not seat. **Note:** Self-Drilling Screws are required to drill their own hole in the correct test plate.

C. Tighten 5 pieces until screw twists into 2 or more pieces or strips out. Record the 5 values and calculate the average. Multiply that average by .80 (80%) to determine the "Test Tightening Torque." **Note:** An optional calculation is to multiply the sum of the 5 failure values by .16 (16%).

D. Seat the 8 remaining pieces to the "Test Tightening Torque."

E. Allow parts to sit 24 hours and retighten to the "Test Tightening Torque."

The entire lot fails if any head separates from its shank during the 24 hour period or when retightened.

Failure:

Possible Failure Causes:

- Parts were not baked after electroplating.
- Parts were tightened to too high a value.
- Washers were not used under the head so that the clamp force was not properly distributed or the underhead radius was damaged in tightening.
- Recess is too deep.



7. COMBINATION TEST RECOMMENDATIONS

Purpose of Recommendation: The following 3 or at least 2 of the 3 tests should be done on all tapping screws to determine their acceptability. This combined test will help you to do all 3 in the least amount of time.

Tests: Drive Test.
Drive Torque Test (Thread Rolling Screws only).
Hydrogen Embrittlement Test.

Procedure (per lot):

- A. Place flat washers on 13 screws to insure tension underhead upon seating.
- B. Drive all screws into the specified test plate so that the major diameter of the screw thread protrudes completely through the plate but do **not** seat the parts.
- C. If testing Thread Rolling Screws, record the maximum driving torque and compare to the specification to determine acceptability (Drive Torque Test, Test #4.)
- D. Examine all of the screw threads protruding through the plate. If any of the threads are deformed the lot is rejectable (Drive Test, Test #3).
- E. Tighten 5 of the 13 parts to failure (screws broken into 2 or more pieces). Record the failure values and calculate the sum. Multiply the sum by .16 (16%) to determine the "Test Tightening Torque." Tighten the next 8 or more screws to that value and allow to sit for 24 hours. Retighten the parts to the "Test Tightening Torque" after 24 hours. If any parts break before or while retightening the lot is rejectable.

8. HARDNESS TESTING

Applicable To: All Tapping Screws.
Test Purpose: To analyze parts which have failed one or more of the previously described performance tests.
Apparatus:

- A. Core hardness
 1. Belt sander (S-100).
 2. Standard Hardness Tester (HTR-100).
- B. Case Hardness: Micro-Hardness Tester (MHP-500).

Specification:	All except Self-Drilling Screws	Self-Drilling Screws
Core Hardness:	RC 28-38	RC 32-39
Case Hardness:	RC 45 min.	RC 52-58
Case Depth:	#2 through #6 .002-.007	same
	#7 through #12 .004-.009	same
	¼ and larger .006-.011	same

Minimum Recommended Sample Size: 8 pc. per lot; lot size not to exceed 250,000.

Note: Material shall be from cold heading quality, killed steel wire having 0.13%-0.27% carbon and 0.64-1.71% manganese.



SPECIFIED AXIAL LOAD
AND DRILLING SPEED



LIMIT SWITCH STOPS
AXIAL LOAD & ROTATION

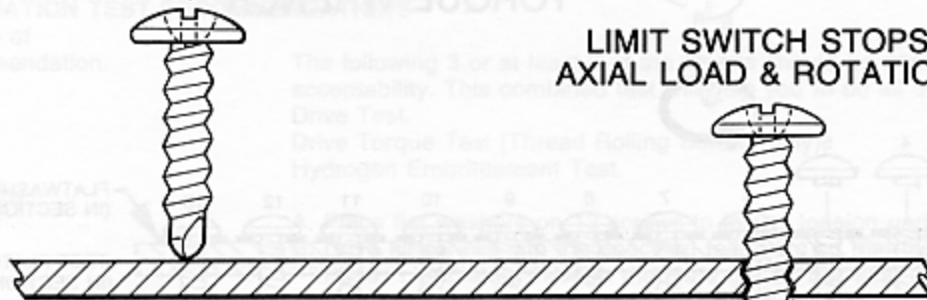
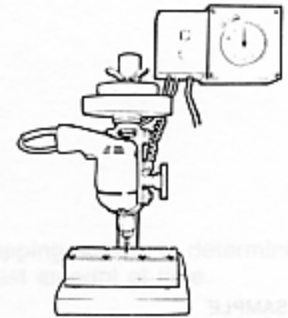

CROSS - SECTIONAL VIEW
OF DRILL TEST PLATE

.060 - .064 THICK
RB60 - 85

MAJOR DIAMETER
THROUGH PLATE, THREADS
COMPLETELY FORMED



TIMER - SECONDS



TIMER - SECONDS

DRILL DRIVE TEST

5. DRILL-DRIVE TEST

Applicable To:
Test Purpose:

Specification:
Apparatus Required:

Minimum Recommended
Sample Size:

Self-Drilling Screws only.

To detect parts which drill too slowly, requiring too much manual effort to drive, or which will not drill at all, causing production problems.

See charts that follow.

- A. Drill Testing Equipment (DST-201).
B. Test Plates .060-.064 thick, RB 60-85.

- | | |
|-------------------------|-----------|
| A. up to 5,000 pc | 6 pieces |
| B. 5,001 to 15,000 pc | 12 pieces |
| C. 15,001 to 50,000 pc | 18 pieces |
| D. 50,001 to 250,000 pc | 25 pieces |

Note: 250,000 is maximum lot size

- E. If 1 piece of the above sample size exceeds the minimum drill time, double the sample size and retest to the sampling plan below.

Sample Size	Slow Drill ₁	Excessive Drill ₂
12	1	0
24	1	0
36	2	1
50	3	1

Note: (1) "Slow Drill" means parts exceeded maximum drill time by less than twice.

(2) "Excessive Drill" means parts exceeded maximum drill time by greater than twice.

Procedure:

- A. Load screws in tester.
B. Adjust tester so that it stops and records the time elapsed as soon as the screw drills its hole and forms 1 full thread beyond the test plate.
C. Record the timed results.

Failure:

Screws fail when they exceed the "Drill-Drive" times specified in the performance chart based on the sampling plan above.

Possible Failure Causes:

- | | |
|----------------------------|-------------------------------|
| A. Burrs on drill point. | E. Test Plate too thick. |
| B. Case Hardness too low. | F. Axial load too light. |
| C. Case Hardness too thin. | G. Driver too slow. |
| D. Test Plate too hard. | H. Excessive Plating Buildup. |

